

CNC-implemented Fault Diagnosis and Web-based Remote Services

Dong-Hoon Kim*

*Department of Intelligence & Precision Machines,
Korea Institute of Machinery & Materials (KIMM), Daejeon 305-343, Korea*

Sun-Ho Kim

*Department of Mechatronics Engineering,
Dong-Eui University, Pusan 614-714, Korea*

Kwang-Sik Koh

*School of Electrical Engineering and Computer Science,
Kyungpook National University, Daegu 702-701, Korea*

Recently, the conventional controller of machine-tool has been increasingly replaced by the PC-based open architecture controller, which is independent of the CNC vendor and on which it is possible to implement user-defined application programs. This paper proposes CNC-implemented fault diagnosis and web-based remote services for machine-tool with open architecture CNC. The faults of CNC machine-tool are defined as the operational faults occupied by over 70% of all faults. The operational faults are unpredictable as they occur without any warning. Two diagnostic models, the switching function and the step switching function, were proposed in order to diagnose faults efficiently. The faults were automatically diagnosed through the fault diagnosis system using the two diagnostic models. A suitable interface environment between CNC and developed application modules was constructed for the internal function of CNC. In addition, a suitable web environment was constructed for remote services. The web service functions, such as remote monitoring and remote control, were implemented, and their operability was tested through the web. The results obtained through this research could be a model of fault diagnosis and remote servicing for machine-tool with open architecture CNC.

Key Words : Open Architecture Controller, CNC, Fault Diagnosis, Remote Services

1. Introduction

During the past few decades, general Computerized Numerical Controller (CNC), which was applied to conventional machine-tool, had a closed architecture, and the CNC was dependent

on the vendor specification. Because of this, it has been very difficult for users to implement an application program in CNC. Moreover, such development environment was not supported. Therefore, it was necessary for an additional Personal Computer (PC) to be connected to the CNC to install user-defined functions in CNC. However, this method inconvenienced the CNC-user of manufacturing system. Recently, the demand for open architecture manufacturing systems and the requirement for high quality CNC have motivated active researches into open architecture CNC (Rober and Shin, 1995; Wright, 1995; Lee et al., 2004). Through such researches, PC-based open

* Corresponding Author.

E-mail : kdh680@kimm.re.kr

TEL · +82-42-868-7148; FAX · +82-42-868-7150

Department of Intelligence & Precision Machines,
Korea Institute of Machinery & Materials (KIMM),
Daejeon 305-343, Korea. (Manuscript Received Sep-
tember 18, 2004; Revised March 22, 2005)

architecture CNC was introduced. Nowadays, machine-tool with open architecture CNC is continuously increasing because of its portability and extensivity of application programs. Real-time monitoring and control via CNC can be implemented for these machine-tools (Kim et al., 2002; Kim et al., 2000; Hong et al., 2003; Tahk and Shin, 2002).

Now, a brief outline of the related researches is introduced. The machine status of each axis were monitored and controlled by interrupting signals between the CNC and electric actuators (Rober and Shin, 1995). A Digital Signal Processing (DSP) board, which is connected to sensors installed with CNC, was used for real-time control of machine-tool (Erol, 2000). A study on integration of process monitoring and optimized interpolation of each axis has been reported (Yellowley and Pottier, 1994). Also, economic system configurations by servo control using Field Programmable Gate Array (FPGA) have been mentioned (Oldknow and Yellowley, 2001). However, most of the mentioned researches have not focused on CNC-level functional applications but machine's control by interface between hardware devices.

As for research on the management of machine-tool with open architecture CNC in manufacturing systems, there have been studies on rapid part realization in flexible factory systems (Wright, 1995) and automatic configuration and dynamic reconfiguration (Oldknow and Yellowley, 2001). A study on switching function generator addressed the maintenance mechanism of machine-tool with open architecture CNC (Kim et al., 2002).

The research of fault diagnosis for manufacturing devices such as gas turbines (Guasch et al., 2000), flexible manufacturing system (Hu et al., 2000; Zhou et al., 2000), and textile plant (Hu et al., 1999) were reported. And remote control of machine-tool by client-server environments was mentioned (Kim et al., 2000; Kang and Kang, 1999). The representative examples for such remote services were factory windows and remote systems developed by a commercial CNC vendor. However, these systems were characterized by

basic technical support in local domain environments.

This paper proposes CNC-implemented fault diagnosis and web-based remote services for machine-tool with open architecture CNC. In machine-tool with open architecture CNC, the fault is diagnosed by using diagnostic models, and diagnosed results are transferred to clients through the web. If the fault is recovered by operator, and current status is monitored through the web, for remote operating, machine-tool can be remotely controlled. Most of the proposed technologies are implemented in CNC in the form of an application program.

In this research, faults were defined as operational faults that were occupied by over 70% of all faults. The faults were unpredictable as they occur without any warning. Two diagnostic models, the Switching Function (SF) and the Step Switching Function (SSF), were proposed in order to diagnose faults efficiently. The faults were automatically diagnosed from Fault Diagnosis System (FDS) with these diagnostic models. A suitable interface environment between CNC and an application program was constructed to apply the developed system to the internal functioning of CNC. Also, a suitable web environment was constructed to service remotely diagnosed results. The web service functions, such as remote monitoring of diagnosed results and remote control of machine-tool, were implemented and their operability was tested through the web.

2. Structure of Open Architecture Controller (OAC) in Machine-Tool

The general OAC has its functional configuration as shown in Fig. 1. The Numerical Controller Kernel (NCK), the Man Machine Interface (MMI), CNC, and the Programmable Logic Controller (PLC) have the same functions as the conventional Numerical Controller (NC). OAC, however, is characterized by a flexible structure which allows the implementation of application programs in CNC. For fault diagnosis and web-based remote services, these basic functions need

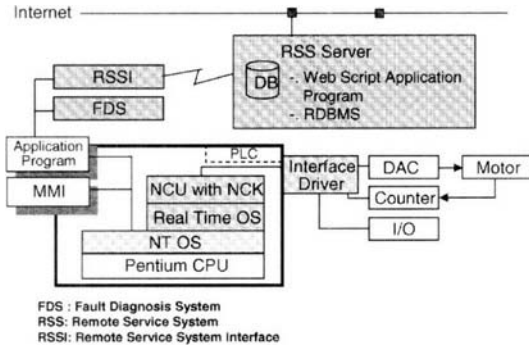

Fig. 1 Function diagram of OAC in machine-tool

two additional functions such as FDS and Remote Service System (RSS). FDS, which is internally implemented within the open architecture CNC, can search for the cause of a fault when a fault occurs. For remote services, RSS enables communication with an external system in order to transmit and receive the current status of machines and the diagnosed results. The major reason to use dual architecture such as FDS and RSS is to reduce communication problems and support real-time diagnosis. For instance, if FDS is executed on an external network, network troubles can occur by unstable communication session and network congestion. Because FDS has to be continuously connected with open architecture CNC in order to obtain necessary data, such as input and output signals of the PLC, for fault diagnosis.

3. Fault Diagnosis System and Remote Service System

The faults of CNC machines are classified into two categories. The first includes faults that occur due to function degradation resulting from the aging phenomena of parts and the second includes faults that occur during general operation. But the second is more interesting as it is unpredictable (Kim et al., 2002). The disability cause of CNC machines controlled sequentially by CNC and PLC can be regarded as the operational faults. They are defined as follows:

(1) Emergency Stop Error (ESE): a sudden stop during operation

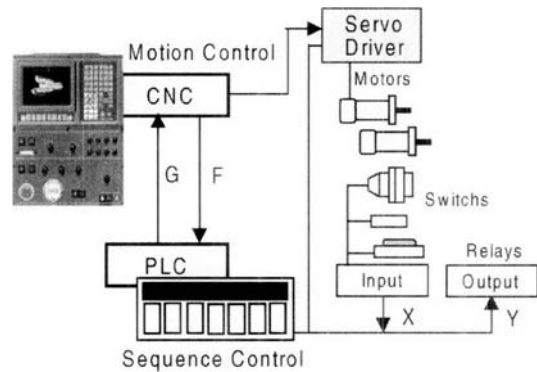

Fig. 2 Interconnected signals of PLC and CNC

(2) Cycle Start Disability (CSD): failure to start

(3) Machine Ready Disability (MRD): the case of no ready state in machine condition

Here, it is proposed a fault diagnosis technology which uses an efficient diagnostic model able to search quickly and identify correctly the causes of the mentioned faults. This makes it possible for beginner operators to easily find the cause of occurring faults. Also, it is proposed remote services technology which provides the diagnosed result along with the current status of machine-tool through a web browser.

3.1 Fault Diagnosis System (FDS)

FDS is an application program that searches for the cause of a fault when a fault occurs. Generally, PLC ladder diagram can be based on the efficient diagnosis for machine-tool which is sequentially controlled by PLC and CNC (Hu et al., 1999). Because many important input/output signals are interconnected between PLC and CNC as shown in Fig. 2, and most data processing is actually executed within PLC although faults occur in CNC or servo motor.

Fig. 3 shows an example of a PLC program called the ladder diagram. This figure presents that it is very difficult to analyze the PLC ladder diagram. That is because the PLC program expresses logical relationships of all signals, and the relationship is so complicated. Also, PLC has a step structure, and it is difficult to find the program faults quickly. Therefore, FDS is

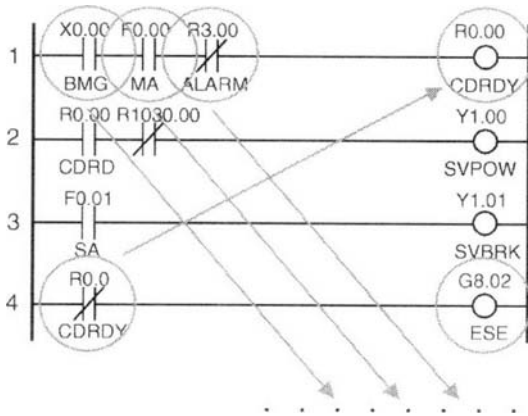

Fig. 3 PLC ladder diagram of emergency stop error (G8.02)

certainly required to solve this problem and to find quickly and exactly the cause of faults through a logical mechanism. For an efficient diagnosis of the cause of faults, two diagnostic models were applied to FDS. The models, SF and SSF, were used in order to express the relationship between input and output signals. The main reason of utilizing a diagnostic model was to allow the generalization to the diagnostic method (Kim et al., 2002).

3.1.1 Switching Function (SF) model

To diagnose the faults of machine-tool, first, the condition of the fault occurrence should be expressed in a logical model. As a static model to diagnose the fault, the SF model has several cases of conditions to satisfy faults. The condition to be satisfied to complete one operational unit of PLC is expressed in Eq. (1) as follows :

$$C(t) = C_1(t) \cdot C_2(t) \cdot C_3(t) \cdot C_4(t) \cdots = \prod_j C_j(t) \tag{1}$$

Here, it is assumed that $C(t)$ is the combination of all conditions of the t -th step. Also, if the t -th step is the last step, $C(t)$ is defined as a switching function. Namely, as a model that expresses the relationship between the input and the output signal until the condition of fault occurrence is satisfied, SF is a static model with ' $C(t)=0$ ' or ' $C(t)=1$ '.

3.1.2 Step Switching Function (SSF) model

SSF is a model that searches for the cause step of fault occurrence by gradually expressing conditions to be satisfied with the cause of fault occurrence. In order to satisfy $C(t)$ as true in Eq. (1), $C_1(t)$, $C_2(t)$, $C_3(t)$, ... should be sequentially satisfied. Here, $C_j(t)$, the condition to be satisfied in each step, is defined as the step switching function. Namely, as a model to find the cause step of a fault occurrence, SSF is a dynamic model with 'IF $C_1(t)=1$ then $C_2(t)$ start Condition'.

Many signals, including input and output of PLC, are interconnected by 'OR' and 'AND' logic in order to complete one operational unit of PLC. For an efficient fault diagnosis, FDS makes use of these diagnostic models to express logical relationships between the input and output of PLC signals. FDS generates diagnostic models through 4 stages as follows. First, the binary code of a PLC ladder diagram is converted to an Instruction List (IL). Second, the SF-list is generated by interpreting IL. Third, a specific SF that is a condition of a specific output signal such as ESE, CSD and MRD, is extracted from the SF-list. Finally, the equation of SF is divided into SSFs by a symbol such as parenthesis.

Through the mentioned process, FDS creates a logical model such as the SF and SSF. The SF model of ESE (G8.02), shown in Fig. 3, is expressed in Eq. (2) as follows :

$$\begin{aligned} \text{SF (ESE, G8.02)} &= ((((-X0.00) + (-F0.00) + (((((-X0.06) \\ &+ (((X0.1C) + (-X0.1D) + (X0.1E)) \\ &* ((((-X0.1C) + (X0.1D) + (-X0.1E)) \\ &* (((X0.1C) + (X0.1D) + (-X0.1E)) \\ &* ((-X0.1C) + (-X0.1D) + (X0.1E)))))))))) \\ &* ((-X1.07) + (-X1.09) + (-X1.0A) \\ &+ (-X1.0C) + (-X1.0D) + (-X1.0F)))))) \end{aligned} \tag{2}$$

This means that '+' is 'OR' logic and '*' is 'AND' logic. Many signals are connected by 'OR' and 'AND' in the SF equation. From this SF, a number of SSFs are generated. As shown in Fig. 4(a), they are the results obtained by dividing the SF equation into 11 SSFs group by parentheses. And 11 SSFs obtained from SF (ESE) equation,

are internally connected by 'OR' or 'AND' logic in the multi-level as shown in Fig. 4(b). To briefly express this complicated SF equation in the form of a tree, each SSF is expressed as a symbol 'S' and its index. Each signal that belongs to SSF, which is already defined in the signal description file, is expressed as a number such as '1', '2', '3' ..., '21'. Therefore, SF (ESE) of Eq (2)

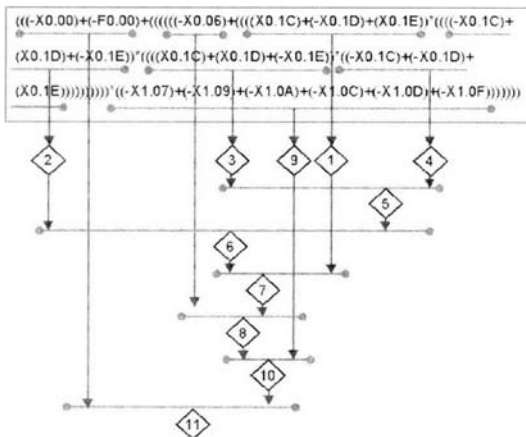

(a) Dividing SF into 11 SSFs

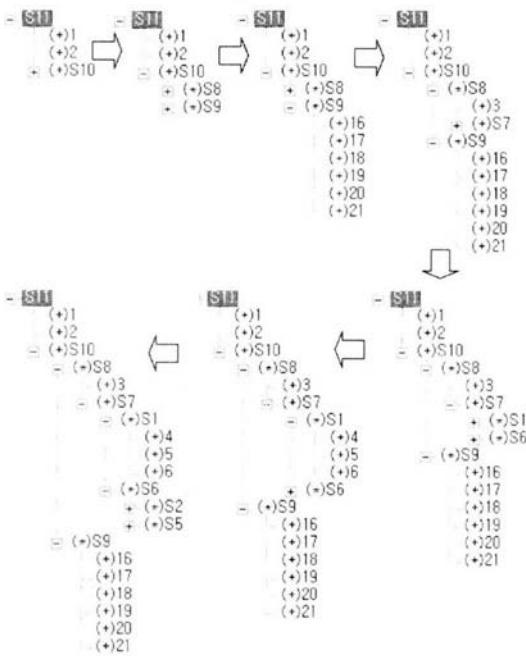

(b) SSF-tree

Fig. 4 SF and SSF-tree of emergency stop error (G8.02)

is briefly expressed as S11. Here, S11 has S10 and two signals, called '1' and '2', which are directly connected to S11. And S10 has 9 low-ranking SSFs from S9 to S1. Similarly, Each SSF has another SSF or several signals.

The flow of fault diagnosis by FDS using the diagnostic models is shown in Fig. 5. First, the SF and SSF models, which are equation models having a logical relationship between the input and output signals of PLC, are automatically created by the program. Second, a specific SF equation that expresses a fault condition of the specific output signal such as ESE (G8.02), is defined from the SF-list. And then, many SSFs are classified from the specific SF.

Third, if it is assumed that the highest step, S11, is the last step of the fault condition, fourth, until the fault step is found, it is continuously processed backward from the last step to the first step to find whether the current step is satisfied as true or not. Finally, if the fault step is found, the cause signal of the fault occurrence is found by comparing the sign of the specific signal with the real value of CNC shared memory.

Figure 6 shows a practical operation of FDS that is internally implemented to the CNC. FDS reports the result, the cause signal of fault occurrence, obtained by searching backwards for the conditions to be satisfied as a fault occurrence. Specifically, this means that the X0.00 signal, which is defined as an emergency stop button, is the cause signal of the fault occurrence when ESE

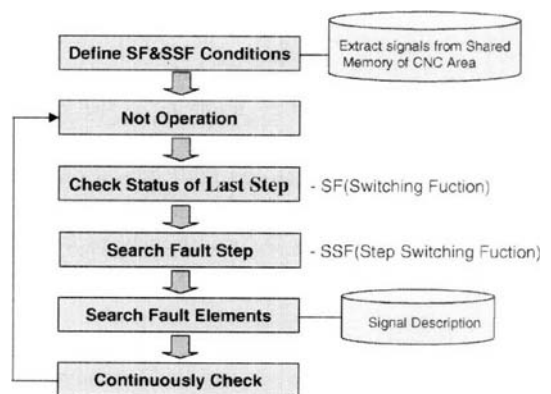

Fig. 5 Step flow of fault diagnosis

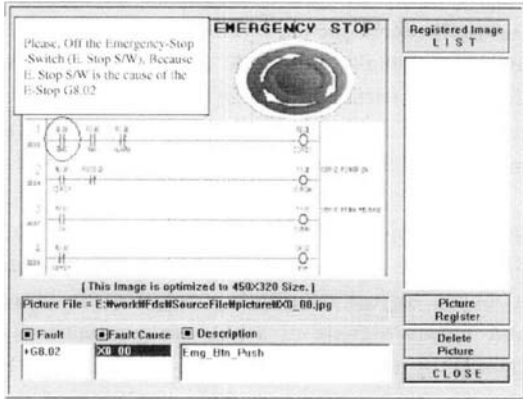

Fig. 6 FDS implemented in CNC controller

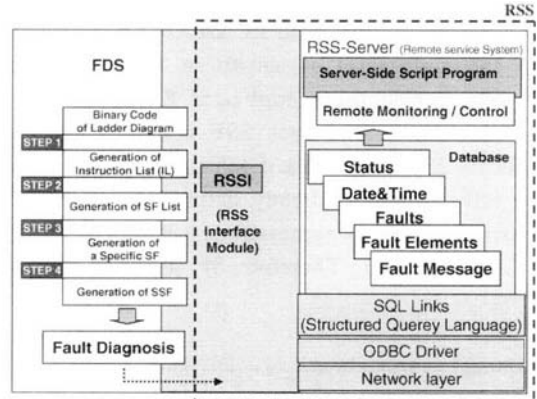

Fig. 7 Structure of RSS

occurs.

For instance, in Eq. (2), G8.02, one of PLC output signals, consists of many X signals, which are the input to the PLC, and one F signal, which is the input from CNC to PLC. Here, first, the real values of these signals are read from CNC shared memory by Application Programming Interface (API) function. Then, S11 shown in Fig. 4, which is the last step of SF and also the highest SSF model, is evaluated to see whether the equation of S11 is satisfied as the true condition of fault occurrence or not by comparing the values of equation signals with real values.

In detail, S11 is the last step, and it is defined as '1+2+S10'. Here, according to the already defined database for signal description, '1' means the $-X0.00$ signal and '2' means the $-F0.00$ signal. Also, 'S10' means the next step and also means another SSF that is located in the lower level than S11. This means that these 3 items, '1', '2' and 'S10', are related by 'OR' condition. Here two signals have all minus signs meaning that these signals are 'NOT'. Therefore, if the signal value of X0.00 or F0.00 is zero (OFF), the signal can be considered to be the fault condition and it is selected as the cause of the fault. If not, however, the searching is continuously processed at the S10 level, which is the next step.

3.2 Remote Service System (RSS)

RSS supports remote services such as the monitoring of diagnosed results obtained from FDS,

the control of CNC machines and feedback monitoring of the current status after control. As shown in Fig. 7, RSS is composed of the RSS Interface module (RSSI), which is implemented in FDS as the CNC internal function on OAC, and a server-side script program that is implemented in the web server. RSSI has the role of interfacing data between the FDS and RSS server by transmitting the result data obtained from FDS and the current status of machines to the server for multi clients that are connected to the Internet.

For connections to a database that is located in a remote site, Open Database Connectivity (ODBC) is used as a standardized method with ActiveX Data Object (ADO). The data processing is executed by a structured query language (SQL) that is a standard language for databases. By using the mentioned process, monitoring data and diagnosed data are created as a structured table in the inside of database. For web-based applications, server-sided web service programs execute remote service functions through a real-time monitoring of diagnostic results and machine status. These service functions present an useful information of machine-tool, such as fault contents and current status, in response to clients connected to server. The results are transmitted to each client in the form of Hyper Text Markup Language (HTML) document through the web browser. Through the mentioned processes, RSS has a role of serving remote monitoring continu-

ously.

4. Interface Between CNC and Application Modules for CNC Implementation

The environment for implementing FDS function to CNC domain utilizes the method of sharing CNC shared-memory with the input and out-

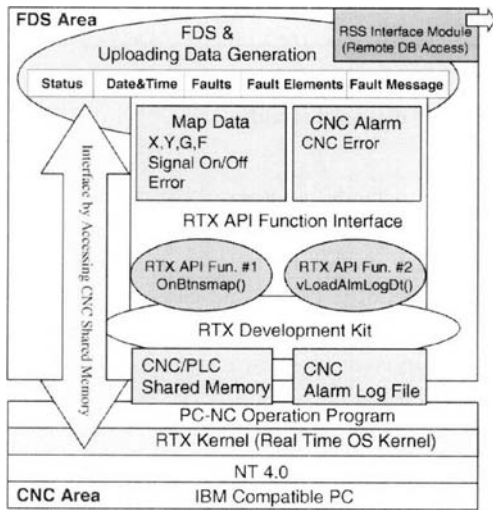
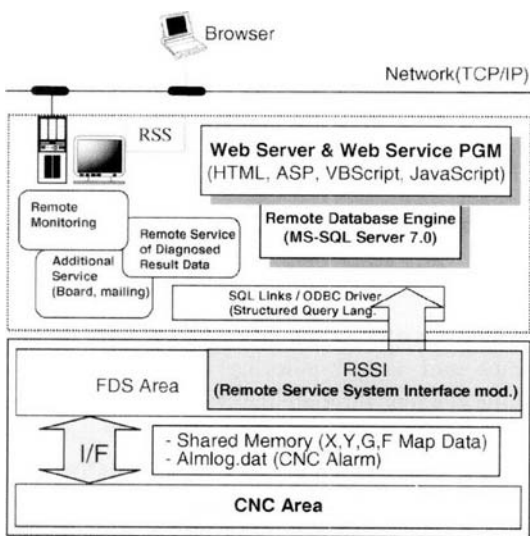

Fig. 8 Interface between FDS and CNC domain

put signals of PLC. And the alarm log file with CNC alarm information is used. The environment is designed for one platform type that can support the real-time sharing of data in PC-based open architecture CNC. The configuration for interfacing between the FDS and CNC domain is schematically given in Fig. 8. The real-time kernel (RTX) is used for the purpose of solving the problem of speed depreciation influenced by accessing many signals and the purpose of executing real-time data processing.

The PLC signal map and CNC alarm data are accessed by using API functions of RTX. The map data, such as the X, Y, G, F, and On/Off information of each signal, are immediately updated by the proposed interface method. They are the exchange information between CNC and PLC. X is an input signal and Y is an output signal of PLC. G is the output signal from PLC to CNC and F is the input signal from CNC to PLC. The internal CNC alarm information, such as the CNC fault, is also updated by the interface method. When the operational fault occurs, the information extracted from the mentioned process is used as a reference datum for the true or false of the SF equation. The signal of the fault cause, the diagnosed result in FDS, is transmitted to an external system by RSSI as shown in Fig. 9. The RSSI module communicates between FDS and RSS server and this module was implemented as the FDS internal function in CNC domain.



I/F: Interface by accessing to shared-memory of CNC

Fig. 9 Interface between RSS and FDS on CNC

5. Web-based Remote Services for Monitoring of Diagnostic Results

The client connected to the Internet can receive web services for monitoring of the current status and diagnosed results of fault. The application of web service by RSS is shown in Fig. 10. Five information columns, such as [Status], [Date & Time], [Faults], [Fault Elements] and [Fault Message], are displayed. First, [Status] means the current status of machine and has three states such as 'Normal', 'Fault' and 'Recovery'. Second, [Date & Time] means the point of time that the status is changed. Third, [Fault] means the kind of fault such as ESE, CSD and MRD. Fourth,

Machine Code : M01PS0004

	Status	Date & Time	Faults	Fault Elements	Fault Message
	Normal	2002-08-06, 18:46:11	None	None	No Fault
(6)	Recovery	2002-08-06, 18:46:10	ESE	None	Recovery Done
(5)	Fault	2002-08-06, 18:46:09	ESE	X0.00	[EStop PB] Signal Error
(4)	Normal	2002-08-06, 18:11:32	None	None	No Fault
	Recovery	2002-08-06, 18:11:31	ESE	None	Recovery Done
	Fault	2002-08-06, 18:11:27	ESE	X0.00	[EStop PB] Signal Error
	Normal	2002-08-06, 18:11:26	None	None	No Fault
(3)	Recovery	2002-08-06, 18:10:46	CSD	None	Recovery Done
(2)	Fault	2002-08-06, 18:09:14	CSD	X0.1D	[Jog Mode s/w] Signal Error
(1)	Normal	2002-08-06, 15:22:06	None	None	No Fault
	Recovery	2002-08-06, 15:22:05	ESE	None	Recovery Done
	Fault	2002-08-06, 12:20:49	ESE	X0.00	[EStop PB] Signal Error
	Normal	2002-08-06, 11:22:33	None	None	No Fault

Row 13 Data is listed

Fig. 10 Web-based remote monitoring of diagnostic results

[Fault Elements] means a diagnosed result. That is the cause signal of fault. The machine status and diagnosed results are periodically offered to clients by RSS-server whenever the information is updated. The current status of machine-tool is displayed from the bottom to the top as shown in Fig. 10.

For example, if 'CSD', cycle start disable, occurs, the useful information is displayed as follows. If no fault at ordinary times, 'Normal' is displayed in [Status] column as row (1) of Fig. 10. However, if a fault occurs, the status is changed from 'Normal' to 'Fault'. Therefore, 'Fault' is newly displayed in [Status] column and related data, such as the kind of fault and the cause of fault, are also displayed in row (2) of Fig. 10 as follows.

"Fault — 2002-08-06, 18 : 09 : 14 — CSD — X0.1D — [Jog Mode S/W] Signal Error"

Here, 'Fault' is the current status of machine and '2002-08-06, 18 : 09 : 14' means the time that the fault occurs. 'CSD' means one of the operational faults and X0.1D, one of PLC input signals, means a diagnosed result for CSD fault. This means that the switch of jog mode in CNC panel, which is connected to the X0.0D defined in PLC signal description, is the cause of the CSD fault. For recovery and cycle start, the mode switch should be changed to another mode such as an auto mode. Besides, if CSD fault is not cancelled although the mode switch is changed

to the auto mode, another cause is still in existence. Through continuous experiment, it was confirmed that another signal such as 'Z axis — over limited' could be the second cause of CSD fault.

For an example of another fault, ESE, emergency stop error, is shown in row (5) of Fig. 10 as follows.

"Fault — 2002-08-06, 18 : 46 : 09 — ESE — X0.00 — [E. Stop PB] Signal Error"

Here, 'Fault' is the current status and '2002-08-06, 18 : 46 : 09' means the time that the fault occurs. 'ESE' means a detected fault and X0.00 means a diagnosed result for ESE. This means that the button for emergency stop, which is connected to the X0.00 defined in PLC signal description, is the cause of the ESE. For recovery, the pushed button for emergency stop should be released.

6. Web-based Remote Services for Control of CNC Machine

After recovering an operational fault of machine-tool and monitoring the recovered machine's status through the web, in some cases, CNC machine needs to be automatically controlled by remote start and stop in the external site. In order to control the machine remotely through web, interface protocol for communication should be defined between open architecture CNC domain and web server domain. As shown



Fig. 11 Interface protocol for remote control

in Fig. 11, the 4-bit command format for control is defined to control CNC machines. Also, the 8-bit command format for monitoring is defined to check the feedback data of the current status after executing the control command.

The method for interfacing between two domains is to make use of common fields within database which is located in server domain. For control of the CNC machine, by using ODBC interface and query language, daemon program running in PC-based open architecture CNC is always checking the control-fields of remote table which is designed for remote control by server-side script program. The daemon program is designed for communication with external server and interpretation of the mentioned command formats. For feedback data monitoring of the CNC machine after control, daemon program updates feedback data of monitoring-fields in a remote table. Sometimes, CNC operating program installed by CNC vendor must be partly edited because the definition of the command format for remote control is related to the specified device's NC program.

In this experimentation, the command for remote control consisted of NC Start, NC Stop, NC Reset and NC Single Block Run. Fig. 12



Fig. 12 Web-based remote control of machine-tool

shows a practical application example, and presents that CNC machine was remotely stopped through the web in external site. The feedback data presents that CNC operational mode is auto mode with remote control enabled position. In order to control CNC machine remotely through the web, the current status of the machine has to be first checked, and then the command button has to be selected. The mentioned commands are executed by user input through the web browser. If necessary, reserved functions, such as remote start and stop commands by scheduling, can be executed according to the assigned date and time.

By visual real-time monitoring through a web browser, these operations are simultaneously and visually monitored to see whether the machine is remotely working or not. For this processing, a web camera was installed to the machine and the script code for video-streaming technology was inserted in the developed application program for the testing of the web services.

7. Results and Discussion

The troubles of CNC machine tools have CNC faults and operational faults. The operational faults occur unpredictably under all possible conditions including faults related with components and sensors, and the manipulation errors of operators. When a CNC fault occurs, the CNC itself generally provides a diagnostic function. For an operational fault, however, the CNC and the machine-tool vendor have not suitable methods due to various kinds of machine-tool and its application environment in machine shop-floor. Hence, when an operational fault, being a cause of disabling the machine operation, occurs, the outside technical maintenance personnel generally visit the field to diagnose the cause of the

fault. That method requires a considerable loss of time and cost. To improve the method of searching for a fault, in this study, a new technique was proposed for diagnosing the causes of operational faults in machine tools with an OAC. To detect exactly the cause of a fault, diagnostic models based on PLC ladder information were applied because PLC ladder is different at each machine shop-floor and it has the key information related with CNC and peripheral equipment including sensors. The results of the diagnosis were displayed on a CNC monitor for machine operators. The results can also be viewed at a remote site through a Web browser. The practical test in model plants located at Chungwon, Daejeon, Kwangjoo and Changwon was performed as shown in Fig. 13. To sum up, the proposed diagnostic method and its results were especially useful to unskilled machine operators and reduced the machine downtime. The downtime wasted in searching for the cause of operational faults in the shop-floor was reduced by approximately 80 percent according to the report of machine-tool A/S center of 'T' Co. Ltd., Chungwon. Hence, the visiting frequency of technical maintenance personnel was reduced as one-fifth

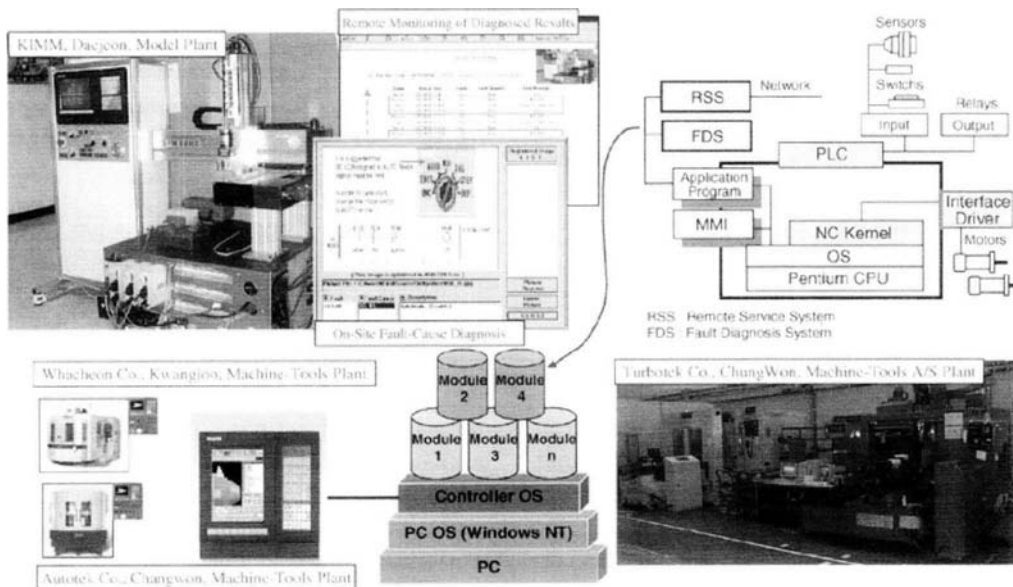

Fig. 13 Practical test of FDS and RSS in model plants

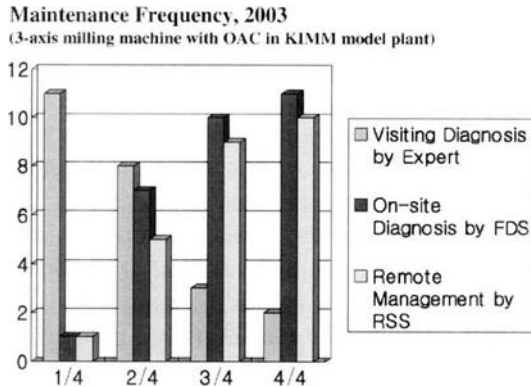

Fig. 14 Maintenance frequency of visiting and on-site

as shown in Fig. 14.

8. Conclusions

This paper proposed the technologies on fault diagnosis using the diagnostic models, the web-based remote monitoring of the diagnostic results, and remote control of machine-tool with an open architecture CNC. The functional application modules for fault diagnosis and interface were implemented within open architecture CNC. Also, web-based global services for remote monitoring and control were realized. The following results are obtained in this research.

(1) A system for fault diagnosis and remote services was implemented and its operability was confirmed through practical examples.

(2) The faults were defined as the operational faults of machine-tool. And two models, SF and SSF, were applied to diagnose operational fault efficiently in FDS.

(3) FDS and RSSI, a diagnosis system for operational faults and an interface module for communication, were implemented in the open architecture CNC as an internal function. The experimental examples were executed for fault diagnosis and web services.

(4) The interface protocol was defined for communication. Practical operation of machines, such as remote control and feedback monitoring, were executed to verify the remote operation in a web environment.

Especially, the diagnosis experiment for operational faults has been performed for two years in CNC machine-tools plant at Kwangjoo and Cheongwon, Korea. Independently of the experience of maintenance experts, prompt and reliable maintenance work was on-site realized in the plants. Hence, it was confirmed that proposed diagnostic method can reduce a machine-downtime remarkably without a technical maintenance personnel.

References

- Erol, N. A., Altintas, Y. and Ito, M. R., 2000, "Open System Architecture Modular Tool Kit for Motion and Machining Process Control," *IEEE/ASME Transactions on Mechatronics*, Vol. 5, No. 3, pp. 281~291.
- Guasch, A., Quevedo, J. and Milne, R., 2000, "Fault Diagnosis for Gas Turbines based on the Control System," *Engineering Application of Artificial Intelligence*, Vol. 13, No. 3, pp. 477~484.
- Hong, W. P., Lee, S. W., Choi, H. Z. and Yang, M. Y., 2003, "Simultaneous 3D Machining with Real-Time NURBS Interpolation," *KSME International Journal*, Vol. 17, No. 3, pp. 336~342.
- Hu, W., Starr, A. G. and Leung, A. Y. T., 1999, "Two Diagnostic Models for Plc Controlled Flexible Manufacturing Systems," *International Journal of Machine Tools & Manufacture*, Vol. 19, pp. 1979~1991.
- Hu, W., Starr, A. G., Zhou, Z. and Leung, A. Y. T., 2000, "A Systematic Approach to Integrated Fault Diagnosis of Flexible Manufacturing Systems," *International Journal of Machine Tools & Manufacture*, Vol. 40, pp. 1587~1602.
- Kang, D. C. and Kang, M. J., 1999, "A Study on an Internet-based Remote Diagnosis System for Machine-Tool Failures," *Journal of KSPE*, Vol. 16, No. 9, pp. 75~81.
- Kim, D. H., Kim, D. Y., Kim, S. H., Han, G. S. and Kim, C. B., 2002, "Development of Switching Function Generator for Fault Reasons of CNC Machine-Tool," *Proceeding of KSMTE Spring Conference*, pp. 48~52.
- Kim, S. H., Kim, D. H. and Park, K. T., 2000, "Open Manufacturing System Using MMS Serv-

ice and Object Oriented Manufacturing Devices,” *Journal of KSPE*, Vol. Vol. 17, No. 10, pp. 41~48.

Lee, D. J., Kim, S. H. and Ahn, J. H., 2004, “Breakage Detection of Small-Diameter Tap Using Vision System in High-Speed Tapping Machine with Open Architecture Controller,” *KSME International Journal*, Vol. 18. No. 7, pp. 1055~1061.

Oldknow, K. D. and Yellowley, I., 2001, “Design, Implementation and Validation of a System for the Dynamic Reconfiguration of Open architecture machine tool Controls,” *International Journal of Machine Tools & Manufacture*, Vol. 41, pp. 795~808.

Rober, S. J. and Shin, Y. C., 1995, “Modeling and Control of CNC Machines Using a PC-based Open Architecture Controller,” *Mechatronics*, Vol. 5, No. 4, pp. 401~420.

Tahk, K. M. and Shin, K. H., 2002, “A study on the Fault Diagnosis of Roller-Shape Using Frequency Analysis of Tension Signals and Artificial Neural Networks based Approach in a Web Transport System,” *KSME International Journal*, Vol. 16. No. 12, pp. 1604~1612.

Wright, P. K., 1995, “Principles of Open-Architecture Manufacturing,” *Journal of Manufacturing Systems*, Vol. 14, No. 3, pp. 187~202.

Yellowley, I. and Pottier, P. R., 1994, “The Integration of Process and Geometry Within an Open Architecture Machine Tool Controller,” *International Journal of Machine Tools & Manufacture*, Vol. 34, No. 2, pp. 277~293.

Zhou, Z. D., Chen, Y. P., Fuh, J. Y. H. and Nee, A. Y. C., 2000, “Integrated Condition Monitoring and Diagnosis for Modern Manufacturing Systems,” *Annals of the CIRP*, Vol. 49, pp. 387~390.